



**Electric motors**

# **2SRC Series**

---

*Three phase synchronous motors*

Powerful, efficient and flexible...

**Technical catalogue**



# Quality management and certificates



VYBO Electric is a modern High-tech energy saving company that pays high attention to quality, environment, safety and precision and efficiency of work and energy in production. Therefore, it holds a lot of certificates and quality control systems. **Our priority is quality control.**

## Basic certificates include:

### ISO9001

The primary task of the ISO 9001 standard is to focus on system management and quality management in the organization. The satisfaction of the customer and the fulfillment of his requirements, which are specified in contracts, orders, or technical drawings, are in the first place. The quality management system is linked to all processes in the company. The standard focuses on the management of human and financial resources, on the stability of infrastructure, including buildings, transport, hardware, software and other communication or information technologies. An important part is also the planning of production and services, the management of the purchasing process, but also the management of non-conforming products.



### ISO14001

The main priority of the ISO 14001 standard is to identify and understand the environmental aspects and activities that are related to the entire infrastructure of the company and, based on this, to regulate the environmental impact on the environment.

In its scope, the ISO 14001 standard creates the conditions for determining environmental goals and plans, the fulfillment of which is examined at regular intervals by top management and also by an independent body during internal audits.

This standard is intended for all organizations and companies that consider environmental protection as their primary goal.

The benefit of the standard for society is mainly:

- control over the environmental impact on the environment
- control over produced emissions and waste
- saving material and energy
- prevention of accidents
- compliance of the company's activities with legal requirements
- zero fines for environmental behavior
- creation of a good reputation and prestige of the company



## The ISO 45001

Specification (formerly known as OHSAS 18001) is an internationally recognized standard that declares compliance with the principles of a safe enterprise, managing risks at work and protecting the health of workers during work. It does not only concern danger and accidents, but also emphasizes other aspects such as the good condition and mental well-being of the employee.

The certificate is held in Slovakia as STN ISO 45001:2019 and is under the title Management systems of safety and health protection at work. Requirements with guidance for use. It replaces the STN OHSAS 18001 standard.



## ISO50001

Energy management systems Energy efficiency help organizations save money, save energy resources and also help to prevent climate change. ISO 50001 encourages organizations in all sectors to use energy more efficiently through the development of an energy management system. The international standard ISO 50001: 2011 specifies the requirements for building, maintaining and improving the energy system. It aims to enable organizations to implement a systematic approach that will help achieve lasting improvements in energy efficiency, energy use and consumption.



## Basic information

These series of metallurgical and crane 3-phase motor 2SRC with slip ring wound rotor are specially used to drive metallurgical crane and other similar machines with better overload capability and mechanical strength. Therefore, it is suitable for short time duty or intermittent periodic duty and equipments with frequent starting and braking or distinct vibration and impact.

The motor can work well when the altitude does not exceed 1000 m.

There are 2 classes of insulation (F and H class). F is applicable to suit temperature which coolant air does not exceed 40°C under normal condition. Class H is suitable for metallurgical sites when ambient temperature no exceeding 60 °C.

The motors possess a better enclosure, degree of protection IP44 for normal site condition and IP54 for metallurgical condition.

Rated voltage and frequency is 380 V and 50Hz.



# Basic information of 2SRC

<b>Phase:</b>	3-phase
<b>Speed:</b>	1000 / 750 / 600 rpm
<b>Frame size:</b>	112 - 400
<b>Voltage:</b>	380 V
<b>Frequency:</b>	50
<b>Protection class:</b>	IP44/IP54
<b>Insulation class:</b>	F/H
<b>Cooling type:</b>	IC 411 cooling (TENV), IC 416 cooling (TEFV)
<b>Temperature:</b>	no more than +40 °C (F class) no more than +60 °C (H class)
<b>Installation height: :</b>	1000 m above sea level

# Product notes

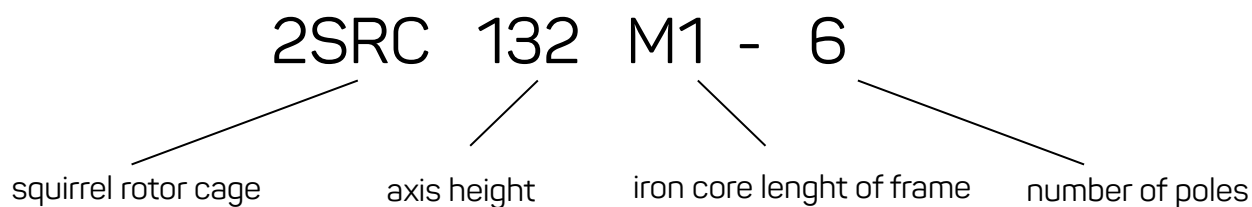

The basic duty of motor is S3-40%, the relation between frame size and degree table below:

Table 1.

Synchron. speed	1000 (r/min)	750 (r/min)	600 (r/min)
Frame size			
112M	1,5	-	-
132M1	2,2	-	-
132M2	3,7	-	-
160M1	5,5	-	-
160M2	7,5	-	-
160L	11	7,5	-
180L	15	11	-
200L	22	15	-
225M	30	22	-
250M1	37	30	-
250M2	45	37	-
280S	55	45	37
280M	75	55	45
315S	-	75	55
315M	-	90	75
355M	-	-	90
355L1	-	-	110
355L2	-	-	132
400L1	-	-	160
400L2	-	-	200



# Product notes

Relations of equal start number with with spot start, brakes and start number:

Table 2.

Duty type	Start & Braking Condition				Equivalent Starts/h
	Starts/h	Point Starts/h	Brakes/h	Bra. & Reve./h	
S3	6	0	0	0	60
S3	4	8	0	0	
S3	2	8	2	0	
S4	150	0	0	0	150
S4	100	200	0	0	
S5	80	0	80	0	
S5	65	130	65	0	300
S5	30	160	30	30	
S4	300	0	0	0	
S4	200	400	0	0	600
S5	160	0	160	0	
S5	130	260	130	0	
S5	60	320	60	60	600
S4	600	0	0	0	
S4	400	800	0	0	
S5	320	0	320	0	600
S5	260	520	260	0	
S5	120	640	120	120	



# Operating Mode and Technical Data

The operation of intermittent periodic duty type is suitable to these motors and it can be divided into below ways according to varied load characteristics:

1. Short time duty (S2): Operation is under constant load in fixed time and the motor is resting when the heat balance is not reached in a period of time. The motor is cooled and the temperature difference between motor and medium is limited within 2K.
2. Intermittent periodic duty (S3): To run according to a series of identical cycles, the running time under constant load and the time of rest are included by period of one cycle (see Fig. 1), but the time is shorter and does not make motor to a heat balance condition. The starting current should be not to affect the temperature rise obviously.
3. Intermittent periodic duty with starting (S4): The run according to a series of identical cycle, each cycle is formed by a starting time, a constant load time and rest time. (see Fig. 2) But the time is short without condition making motor to a heat balance.
4. Intermittent periodic duty with starting and electric braking (S5): It runs according to a series of identical cycle, there are starting time, constant load time, electric quick-braking time and a rest time in each cycle. But the motor cannot reach the condition of heat balance in such short time (Fig. 3).

When you choose the motor, various conditions of starting and braking have to be converted into a equivalent data of starts/hour according to equivalent heat then the motor quota is determined by the equivalent data. The example is shown in Table 2.

When the point start speed is end, the speed does not exceed 25% of rated speed i.e. four times equals ones of starting. Ones electric braking (To brake to one third of rated speed) is equal to 80% of start. The motors in the Table 3 and 4 show the data of delivery condition on the name plate only under basic duty. If you need a duty type out of S2 to S5 the consultation with manufacturer is needed.

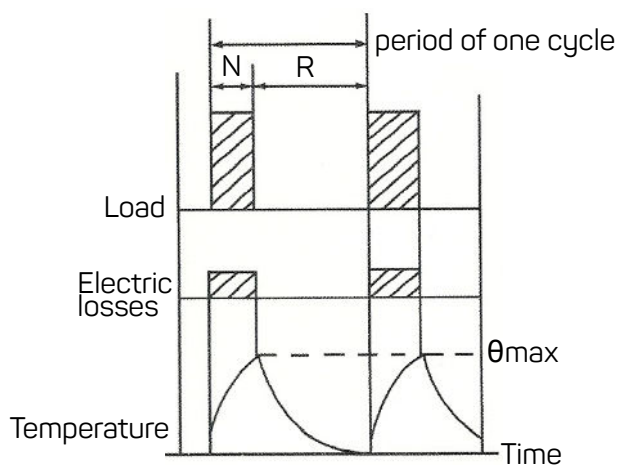

**Fig. 1 Intermittent period duty type S3:**

N = Operation under rated condition

R = At rest and deenergized

$\theta_{max}$  = maximum temperature attained during the duty cycle;

$$\text{Intermittent rate: FC} = \frac{N}{N + R} \times 100\%$$



# Operating Mode and Technical Data

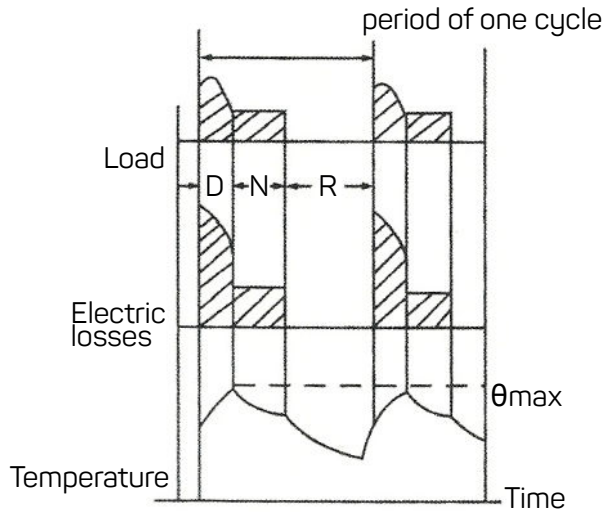

**Fig. 2 Intermittent period duty with starting type S4:**

D= starting

N = Operation under rated condition

R = At rest and deenergized

$\theta_{max}$  = maximum temperature attained during the duty cycle;

$$\text{Intermittent rate: FC} = \frac{D+N}{D+N+R} \times 100\%$$

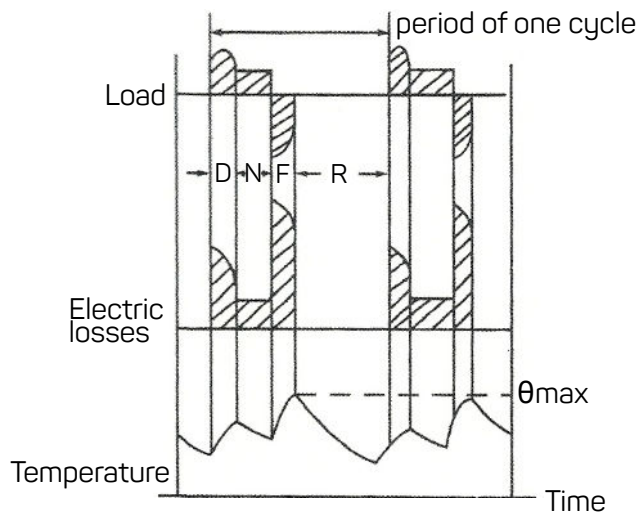

**Fig. 3 Intermittent period duty with starting & electric braking type S5:**

D= starting

N = Operation under rated condition

R = At rest and deenergized

F = Electric braking

$\theta_{max}$  = maximum temperature attained during the duty cycle;

$$\text{Intermittent rate: FC} = \frac{D+N+F}{D+N+F+R} \times 100\%$$



# Technical data of 2SRC series

Table 3.

Frame size	S2 duty type																S3 duty type																Rotor Voltage	Moment of inertia (kg.m <sup>2</sup> )	Weight (kg)	
	30 minutes				60 minutes				15%				25%				40%				60%				100%											
	kW	I1	I2	n	kW	I1	I2	n	kW	I1	I2	n	kW	I1	I2	n	I1	I2	Tm	lo	n	n <sub>1</sub>	cosφ	kW	I1	I2	n	kW	I1	I2	n					
1000 r/min																																				
112M	1.8	5.3	13.4	815	1.5	4.63	12.5	866	2.2	6.6	18.4	725	1.8	5.3	13.4	815	1.5	4.63	12.5	2.5	3.37	866	65	0.77	11	3.8	7.32	912	0.8	3.5	516	940	100	0.028	74	
132M1	2.5	6.5	12.9	892	2.2	6.05	12.6	908	3	8	16.1	855	2.5	6.5	12.9	892	2.2	6.05	12.6	2.86	2.86	4.04	908	70	0.77	18	5.4	8.96	921	1.5	5	73	940	132	0.058	97
132M2	4	9.7	14.2	900	3.7	9.2	14.5	908	5	12.3	18.2	875	4	9.7	14.2	900	3.7	9.2	14.5	2.51	5.58	908	75.5	0.78	3	7.9	10.2	937	2.5	7.5	8.4	950	185	0.065	108	
160M1	6.3	16.4	29.4	921	5.5	15	25.7	930	7.5	18.5	35.4	910	6.3	16.4	29.4	921	5.5	15	25.7	2.56	7.95	930	75.5	0.78	5	14	22.9	935	4	12.5	18.2	944	138	0.118	154	
160M2	8.5	19.6	29.8	930	7.5	18	26.5	940	11	24.6	39.6	908	8.5	19.6	29.8	930	7.5	18	26.5	2.78	11.2	940	79	0.8	6.3	16	21.7	949	5.5	15	18.8	956	185	0.145	160	
160L	13	28.6	31.6	942	11	24.5	27.6	957	15	34.7	39	920	13	28.6	31.6	912	11	24.9	27.6	2.47	13	945	82	0.8	9	21	22.3	952	7.5	18.8	18.5	970	250	0.195	174	
180L	17	36.7	49.8	955	15	33.8	46.5	962	20	42.6	58.7	946	17	36.7	49.8	955	15	33.8	46.5	3.2	18.8	962	84	0.81	13	29.7	37.3	968	11	25.5	31.4	975	218	0.375	230	
200L	26	56.1	82.4	956	22	49.1	74.4	964	33	62	103	942	26	56.1	82.4	956	22	49.1	69.9	2.88	26.6	964	86	0.8	19	44.5	60.5	969	17	40.5	52.6	973	200	0.65	320	
225M	34	70	85	957	30	62	91.5	962	40	80	101	917	34	70	85	957	30	62	74.4	3.3	29.9	962	88	0.82	26	55	64.5	968	22	50	54.2	975	250	0.825	512	
250M1	42	80	103	960	37	70.5	95	965	50	99	123	950	42	80	103	960	37	70.5	91.5	3.13	26.5	960	89	0.89	32	61	79	970	28	55	69	975	250	1.5	512	
250M2	52	97	110	958	45	84.5	95	965	63	121	134	947	52	97	110	958	45	84.5	95	3.48	28.2	965	90.5	0.89	39	73	83	969	33	64	71	974	290	1.75	559	
280S	63	118	142	966	55	101.5	129.8	969	75	144	169.5	960	63	118	142	966	55	101.5	119.8	3	34	969	91	0.9	48	88	107.1	972	40	76	88.9	976	280	2.3	747	
280M	85	157	140	966	75	139	124	970	100	185	166	960	85	157	140	966	75	139	124	3.2	47.5	970	91.8	0.89	63	118	104	975	50	96.3	82	980	370	2.8	848	
750 r/min																																				
160L	9	22.4	28.1	694	7.5	19.1	23	705	11	27.5	35.3	676	9	22.4	28.1	694	7.5	19.1	23	2.73	12.7	705	78.5	0.72	6	16.4	18.2	712	5	14	15	724	205	0.195	172	
180L	13	29.1	47.8	700	11	27	44	700	15	34	56	690	13	29.1	47.8	700	11	27	44	2.72	14.8	700	81	0.77	9	21.9	32.1	720	7.5	19.6	26.6	726	172	0.375	230	
200L	18.5	40	67.2	701	15	33.5	53.5	712	22	48	81	690	18.5	40	67.2	701	15	33.5	53.5	2.94	17.75	712	85	0.78	13	30	46	718	11	27	38.7	723	178	0.65	317	
225M	26	55	71.2	708	22	46.9	59.1	715	33	70	92	696	26	55	71.2	708	22	46.9	59.1	2.96	24.17	715	86	0.79	18.5	41	49.5	721	17	38	45	723	232	0.8	390	
250M1	35	64	80	715	30	63.4	67.7	720	42	75	97.5	710	35	64	80	715	30	63.4	67.7	2.64	31.4	720	87	0.8	26	52	59.1	725	22	46	49.7	729	272	1.5	512	
250M2	42	86	79	716	37	78	70	720	52	106	98	706	42	86	79	716	37	78	70	2.73	36.9	720	88	0.82	32	68	60	725	27	60	51	729	335	1.75	563	
280S	52	108	106	712	45	96.5	92	717	63	129	130	704	52	108	106	712	45	96.5	92	3.17	48	717	88.8	0.8	39	86.2	79.4	722	33	76.3	67	726	305	2.3	747	
280M	63	126	110	722	55	110.5	92.7	725	75	150	132	715	63	126	110	722	55	110.5	92.5	2.85	52.3	725	89	0.84	48	103	82.8	730	40	93	68.7	732	360	2.8	848	
315S	85	164.8	177.8	722	75	146.7	156.7	725	100	162	171.5	85	164.8	177.8	722	75	146.7	156.7	2.94	62	725	89	0.85	63	126.4	130.7	729	55	105.4	104.3	731	302	7.05	1050		
315M	100	190	183.5	715	90	172	160.9	720	125	200	232	717	100	190	183.5	715	90	172	160.9	3.13	57.7	720	90	0.87	75	140	136	725	63	124	113.8	728	372	8.5	1170	
600 r/min																																				
280S	42	92	177.1	517	37	84.8	153.2	560	55	112	235.2	564	42	92	177.1	517	37	84.8	153.2	2.8	44.2	572	86	0.76	32	77	133.4	578	27	69	111.8	582	150	3.5	767	
280M	55	127	207	556	45	103.8	165	560	63	146	241	548	55	127	207	556	45	103.8	165	3.16	63.6	560	86	0.77	37	90	136	569	33	89.6	118	587	172	3.9	840	
315S	63	132	161.9	561.9	55	118.3	138.7	580	75	154	194	574	63	132.5	161.9	580	55	118.3	138.7	3.11	62.5	580	88.5	0.79	48	106.6	122	585	40	95.2	101	588	242	7.05	1026	
315M	85	179	171	576	75	160	149.3	579	100	210	203	570	85	179	171	576	75	160	149.3	3.45	85.3	579	89	0.79	63	140	124.8	584	50	125	98.5	587	325	8.5	1156	
355M	110	218	207	581	90	180	166.6	585	132	266	252	576	110	218	207	581	90	180	166.6	3.33	83	589	90	0.81	75	154	140	588	63	136	117	589	330	14	1520	
355L1	132	257	213	576	110	217	172	582	160	314	261	571	132	257	213	576	110	217	172	3.1	90	582	91	0.82	90	181	143	585	75	157	119	588	388	16.75	1764	
355L2	150	293	194	588	132	262	167.5	588	185	353	241	585	150	293	194	588	132	262	167.5	3.48	126	588	92	0.82	110	226	141.8	591	90	191	115.6	592	475	18.75	1810	
400L1	190	390	290	585	160	338	244	587	220	445	336	581	190	390	290	584	160	338	244	3.02	175	587	91.5	0.79	135	294	206	592	115	268	174	591	395	24	2400	
400L2	240	490	302	585	200	427	252	588	270	540	340	582	240	490	302	586	200	423	252	2.85	213	588	92.2	0.77	170	372	214	591	145	332	183	592	460	27.5	2950	

Table 4.

Frame size	S4 and S5																								Rotor Voltage	Moment of inertia (kg.m <sup>2</sup> )	Weight (kg)
	25%				150 starts / h				40%				60%				300 starts / h				600 starts / h						
	kW	I1	I2	n	kW	I1	I2	n	kW	I1	I2	n	kW	I1	I2	n	kW	I1	I2	n	kW	I1	I2	n			
1000 r/min																											
112M	1.6	4.75	11.3	845	1.3	4.2	8.85	890	1.0	3.75	6.57	920	1.2	4.0	8.0	900	0.9	3.7	5.87	930	0.7	3.4	4.46	946	100	0.028	74
132M1	2.2	6.0	11.2	908	2.0	5.7	10	913	1.7	5.3	8.4	931	1.8	5.4	8.95	926	1.6	5.1	7.87	936	1.35	4.9	6.8	945	132	0.058	97
132M2	3.7	9.7	13.1	915	3.5	9.2	11.2	925	2.8	8.5	9.65	940	3.3	9.4	11.9	925	2.7	8.5	9.65	940	2.3	6.0	7.5	950	185	0.065	108
160M1	5.8	15.5	27.3	927	5.0	14.1	23.4	935	4.8	13.8	22.7	937	4.8	14.1	23.4	935	4.5	13.8	22.4	937	3.8	12.2	17.5	946	138	0.118	154
160M2	7.5	18	27.6	940	7.0	17.1	25.6	945	6.0	15.6	21.8	954	6.0	15.6	21.8	954	5.5	14.8	19.8	959	4.0	13	14.2	970	185	0.145	160
160L	11	28.3	27.8	950	10	23	25	957	8.0	19.5	19.8	969	9.0	19.5	19.8	969	7.5	18.7	18.5	971	6.0	16.7	14.2	978	250	0.195	174
180L	15	33	43.7	960	13	29.5	37.7	965	12	28	34.6	969	12	28	34.6	969	11	26.6	31.7	972	9.0	23.6	22.9	978	218	0.375	230
200L	21	47	55.4	965	18.5	42.5	48.5	9																			





# Technical data of 2SRC series

Mode of cooling:

- Frame 112~132 use the form of natural cooling (IC410)
- Frame 160~400 use the form of self fan cooling (IC411).

The installation and construction is in table 5:

Table 5:

Installation type	Symbol	Range (Frame size)
	IM1001	112~160
	IM1003	180~400
	IM1002	112~160
	IM1004	180~400
	IM3001	112~160
	IM3003	180
	IM3011	112~160
	IM3013	180~315

- The shaft extension can be made according to customers request or dimension.
- Transmission through shaft coupling or spur gear may be used. If the latter is taken, the minimum pitch circle diameter should be not less than double the diameter of shaft extension end.
- Terminal box at the top of frame has two outlet directions along both sided of motor for stator but the rotor's outlet position may be from both sides of end cover.
- The measures are taken to prevent slack on the fastener of motor.
- The brush type is J201 and formats see in Table 6 and 7

Table 6:

Frame size	The dimensions of brush (mm)	The output diameter of slip-ring (mm)
2SRC112	20x8x32	100
2SRC132	20x8x32	100
2SRC160	25x10x40	112
2SRC180	25x10x40	125
2SRC200	32x12,5x50	140
2SRC225	32x12,5x50	140

Table 7:

Frame size	The dimensions of brush (mm)	The output diameter of slip-ring (mm)
2SRC250	40x12,5x50	160
2SRC280	40x20x60	200
2SRC315	40x20x60	200
2SRC355	50x20x60	250
2SRC400	50x20x60	250



# Installation and dimension of series 2SRC112-400 IM1001, 1002, 1003, 1004

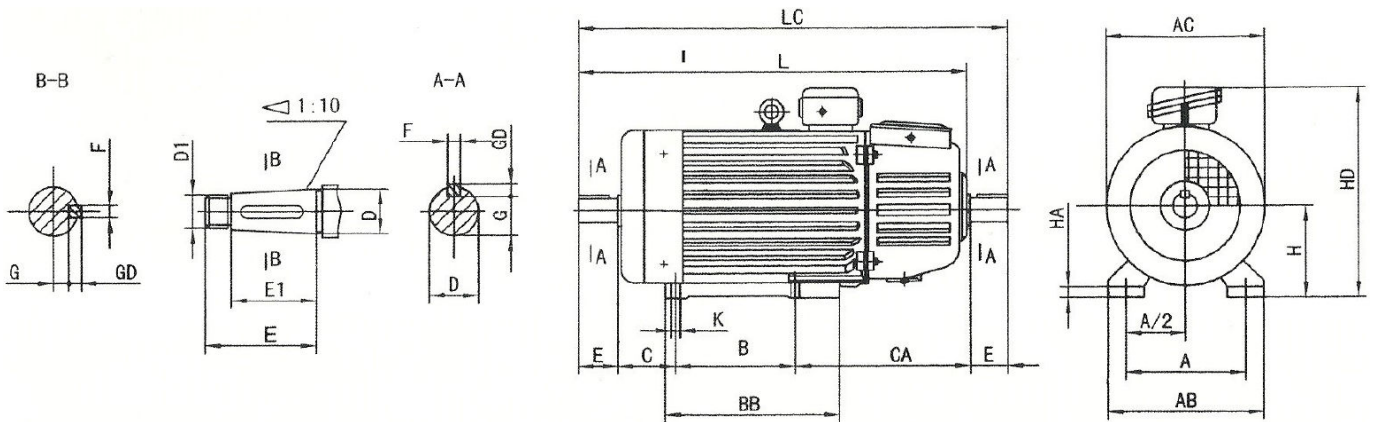

Frame size	Dimensions of Installation													Overall dimensions								
	H	A	B	C	CA	K	Diameter of screw	D	D <sub>1</sub>	E	E <sub>1</sub>	F	G	GD	AC	AB	HD	BB	L	LC	HA	
112M	112	190	140	70	300	12	M10	32		80		10	27	8	245	250	335	235	590	670	15	
132M	132	216	178	89				38					33		285	275	365	260	645	727	17	
160M	160	254	210	108	330	15	M12	48		110		14	42,5	9	325	320	425	290	758	868	20	
160L		254	335	800				912														
180L	180	279	279	121	360			55	M36 x 3	82		19,9		360	360	465	380	870	980	22		
200L	200	318	305	133	400	19	M16	60	M42 x 3	140	105	16	21,4	10	405	405	510	400	975	1118	25	
225M	225	356	311	149	450			65					430		455	545	410	1050	1190	28		
250M	250	406	349	168	540	24	M20	70	M48 x 3			18	25,4	11	480	515	605	510	1195	1337	30	
280S	280	457	368	190				85					M56 x 4		20	31,7	12	535	575	665	580	1265
280M			419																			
315S	315	508	406	216	600	28	M24	95	M64 x 4			22	35,2	14	620	640	750	630	1440	1613	35	
315M			457					110					M80 x 4		210	165	25	41,9	710	740	840	730
355M	355	610	560	254																		
355L			630																			
400L	400	686	710	280		35	M30	130	M100 x 4	250	200	28	50	16	840	855	950	910	1865	2120	45	



# Installation and dimension of series 2SRC112-180 IM3001, 3003

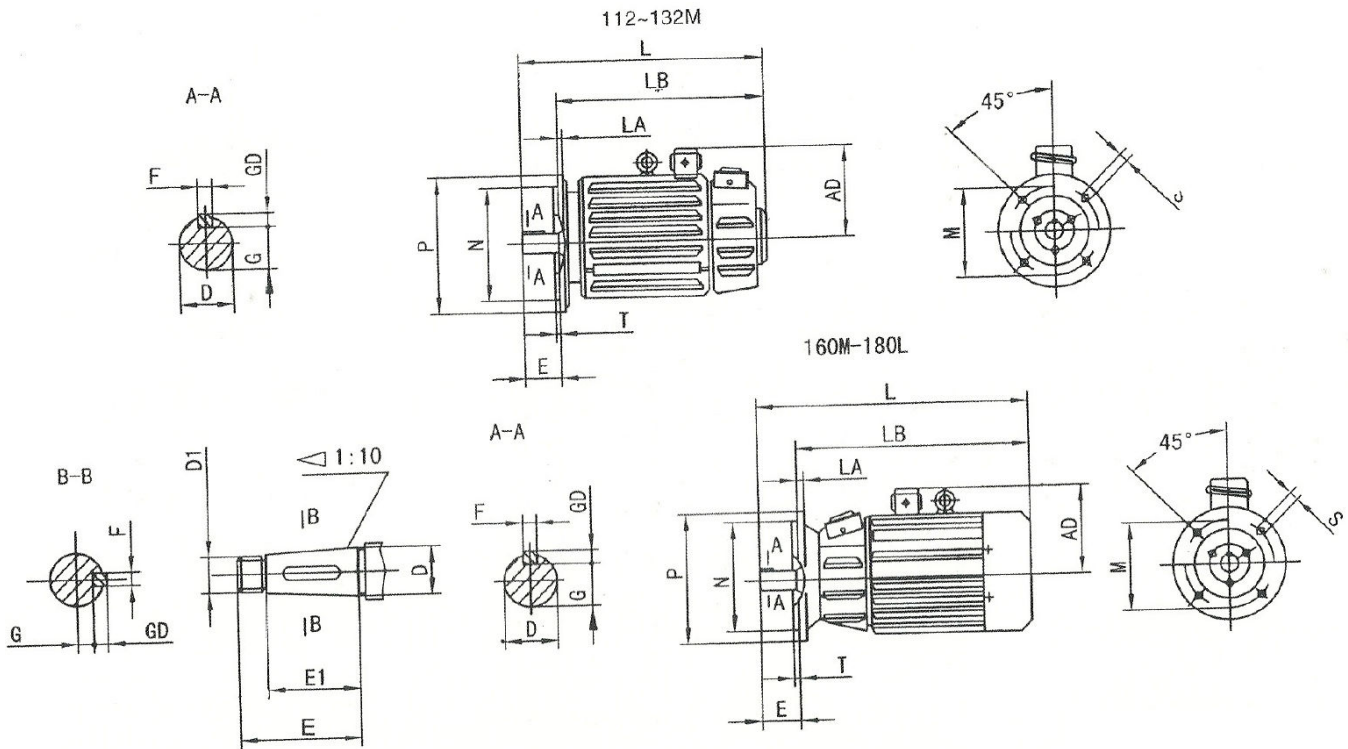

Frame size	Dimensions of Installation										Overall dimensions						
	M	N	P	T	Diameter of screw	Hole number	D	D1	E	E1	F	GD	G	L	LA	LB	AD
112M	215	180	250	4	M12	4	32		80		10	8	27	595	14	515	220
132M	265	230	300				38							33	645		565
160M							48						42,5	828		718	260
160L	300	250	350	5	M19				110		14	9		872	18	762	
180L							55	M36x3			82		19,9	915		805	280



# Installation and dimension of series 2SRC112-315 IM3001, 3003

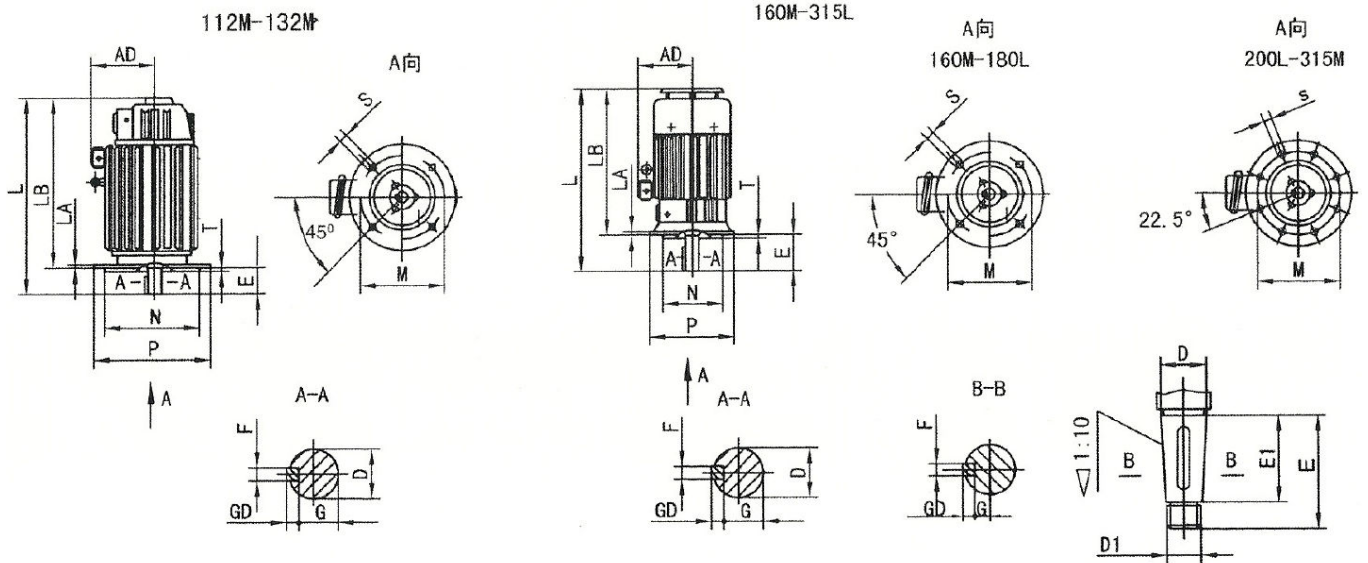

Frame size	The symbol of flange	Dimensions of Installation							Overall dimensions										
		M	N	P	T	S	Diameter of screw	Hole number	D	D1	E	E1	F	G	GD	L	LA	AD	LB
112M	F215	215	180	250	4	15	M12	32		80		10	27	8	595	14	220	515	
132M	F265	265	230	300				38					33		645		230	565	
160M								48							828		260	718	
160L	F300	300	250	350						110		14	42,5	9	872	18	280	762	
180L								55	M36x3				19,9		915		280	805	
200L	F400	400	350	450	5	19	M16	60	M42x3			16	21,4	10	1050	20	320	910	
225M								65		140	105		23,9		1110			970	
250M								70	M48x3				18	25,4	11	1266		355	1126
280S	F500	500	450	550				85	M56x4				20	31,7	12	1370	22	385	1200
280M										170	130				1420			1250	
315S	F600	600	550	660	6	24	M20	95	M64x4				22	35,2	14	1475	25	435	1305
315M															1525			1355	



# Installation and dimension of series 2SRC112-250 IM1001, 1002, 1003

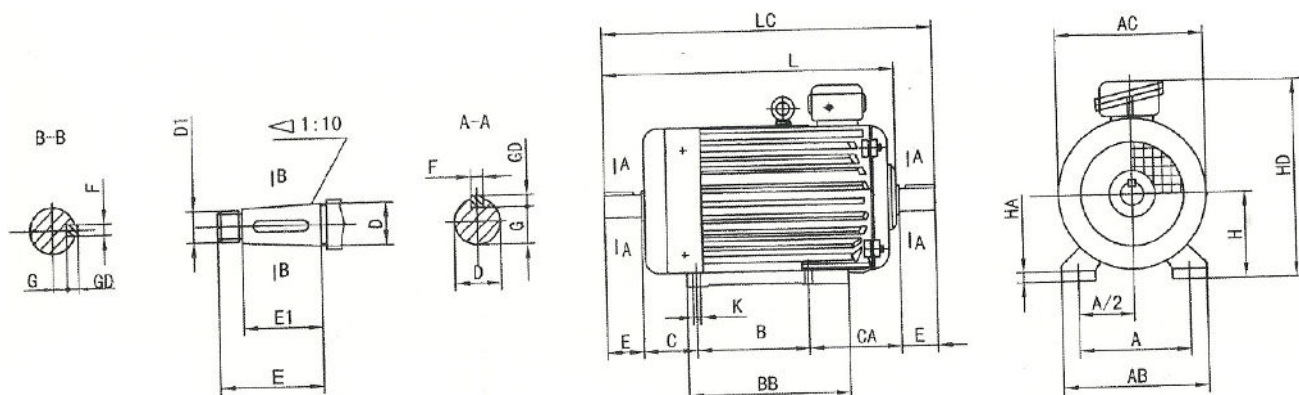

Frame size	Dimensions of Installation														Overall dimensions						
	H	A	B	C	CA	K	Diameter of screw	D	D1	E	E1	F	G	GD	AC	AB	HD	BB	L	LC	HA
112M	112	190	140	70	135	12	M10	32		80		10	27	8	245	250	335	235	420	505	15
132M	132	216	178	89	150			38					33		285	275	365	260	495	577	17
160M	160	254	210	108	180	15	M12	48		110		14	42,5	9	325	320	425	290	608	718	20
160L			254																335	650	762
180L	180	279	279	121				55	M36x3		82		19,9		360	360	465	380	685	800	22
200L	200	318	305	133	210	19	M16	60	M42x3			16	21,4	10	405	405	510	400	780	928	25
225M	225	356	311	149	258			65		140	105		23,9		430	455	545	410	850	998	28
250M	250	406	349	168	295	24	M20	70	M48x3			18	25,4	11	480	515	605	510	935	1092	30



# Installation and dimension of series 2SRC112-180 IM3001, 3003

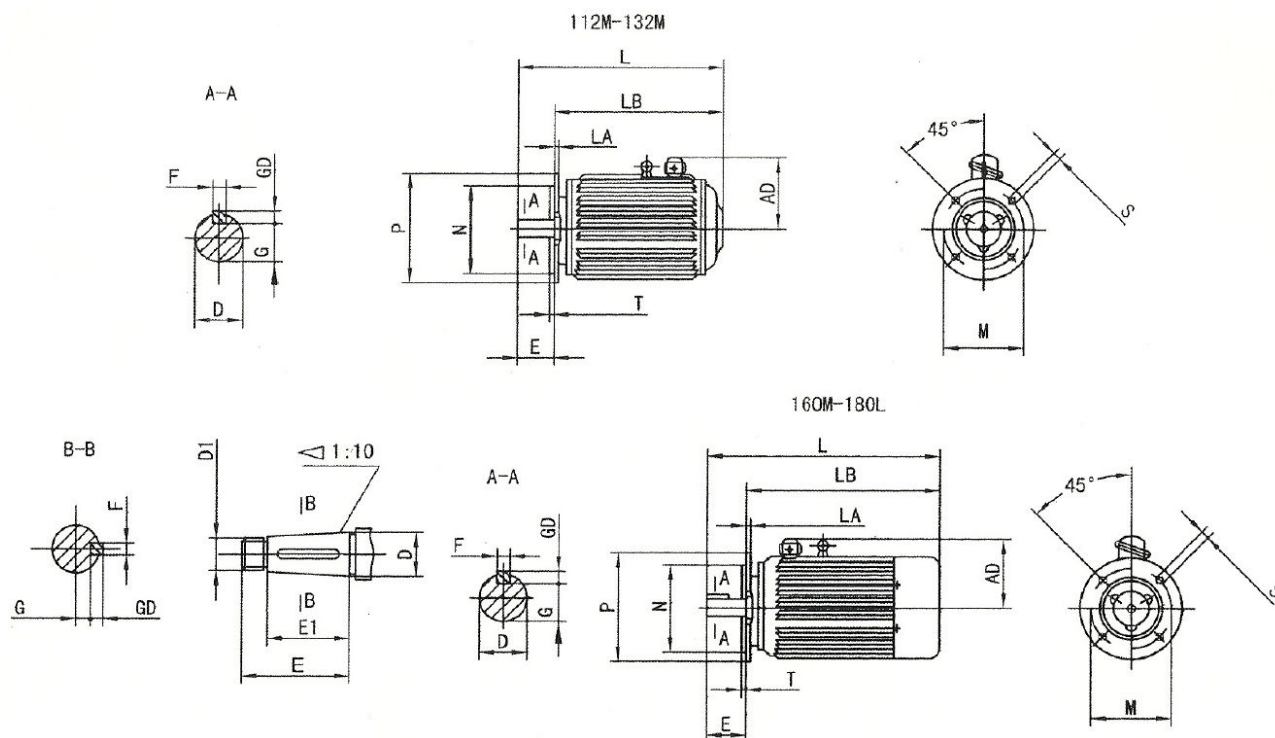

Frame size	The symbol of flange	Dimensions of Installation											Overall dimensions							
		D	D1	E	E1	F	G	M	N	P	R	S	Diameter of screw	T	Hole number	AD	L	LA	LB	
112M	FF215	32		80		10	27	215	180	250							220	430	14	350
132M	FF265	38					33	265	230	300							230	495		415
160M																				
160L	FF300	48		110		14	42,5	300	250	350							260	700	18	590
180L		55	M36x3			82	19,9										280	735		625



# Installation and dimension of series 2SRC112-250 IM3011, 3013

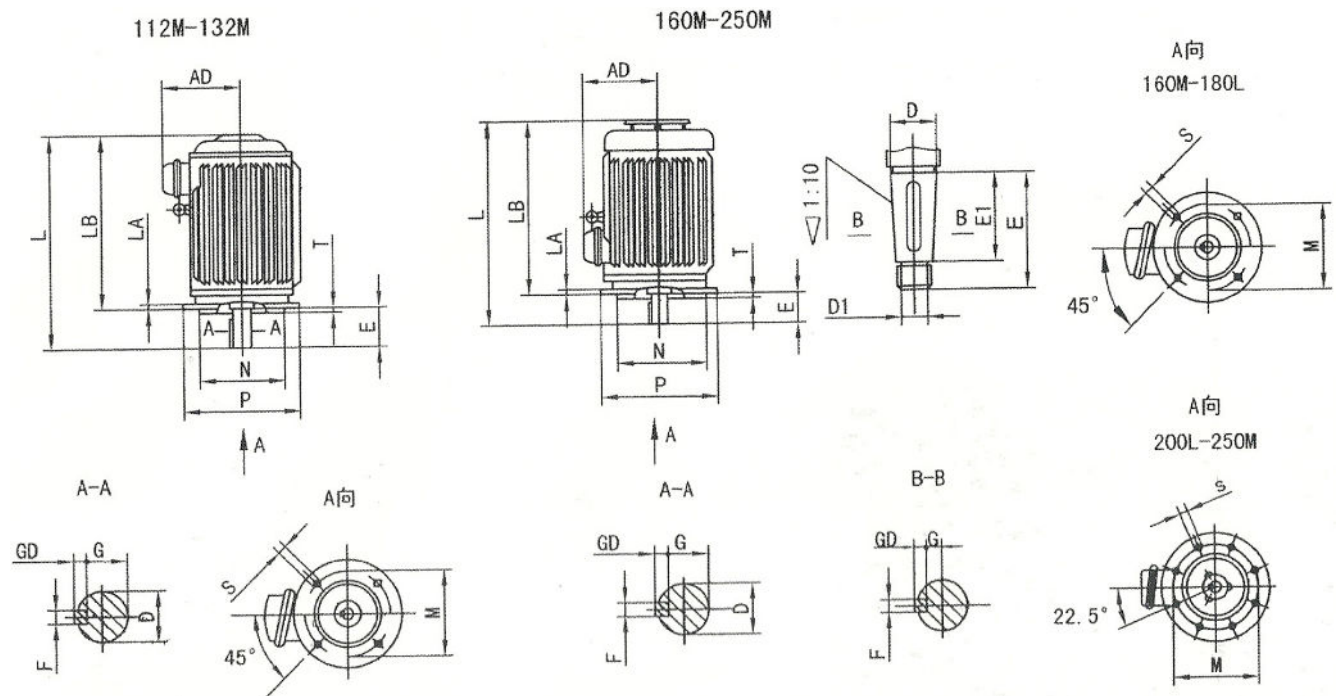

Frame size	The symbol of flange	Dimensions of Installation										Overall dimensions					
		M	N	P	T	S	Diameter of screw	Hole number	D	D1	E	E1	F	G	GD	L	LA
112M	FF215	215	180	250	4	15	M12	32		80	10	27	8	430	14	220	350
132M	FF265	265	230	300													
160M					5	19	M16	48		110	14	42,5	9	700	18	260	590
160L	FF300	300	250	350													
200L	F400	400	350	450	8		60	M42x3	140	105	16	21,4	10	855	20	320	715
225M																	
250M	F500	500	450	550			70	M48x3			18	25,4	11	1005	22	355	865





## Address

VYBO ELECTRIC a. s. | tel: +421 944 105 361  
Radlinského 18 | e-mail: mv@vyboelectric.eu  
052 01 Spišská Nová Ves  
Slovenská republika

[www.vyboelectric.com](http://www.vyboelectric.com)



SOLUTIONS FOR INDUSTRY

BUREAU VERITAS  
Certification



**VYBO Electric a.s.**  
Radlinského 18, 052 01 Spišská Nová Ves  
Slovak Republic

Bureau Veritas Certification Holding SAS – UK Branch certifies that the Management System of the above organisation has been audited and found to be in accordance with the requirements of the management system standards detailed below

### ISO 14001: 2015

Scope of certification

**MANUFACTURE AND SALE OF ELECTRIC MOTORS, SALES AND DEVELOPMENT OF VARIABLE FREQUENCY DRIVES.**

Original cycle start date: 18.05.2022  
Expiry date of previous cycle: N/A  
Certification Audit date: 31.03.2022  
Certification cycle start date: 18.05.2022

Subject to the continued satisfactory operation of the organization's Management System, this certificate expires on: 17.05.2025

Certificate No. SK-U22 055E Version: 1 Issue date: 18.05.2022

Certification body address: 5<sup>th</sup> Floor, 86 Prescott Street, London E1 8HQ, United Kingdom  
Local office: Plynárska 7/B, BRATISLAVA 821 09, Slovak Republic



Further clarifications regarding the scope of this certificate and the applicability of the management system requirements may be obtained by consulting the organisation. To check this certificate validity please call: +421 2 2341 4165

Page 1 of 1



Bureau Veritas Certification

### Certificate

Awarded to

**VYBO Electric a.s.**

Radlinského 18, 052 01 Spišská Nová Ves  
Slovak Republic

BUREAU VERITAS CERTIFICATION (Z) s.r.o. certifies that the Management System of the above organisation has been assessed and found to be in accordance with the requirements of the management system standard detailed below

Standard

### ISO 45001:2018

Scope of supply

**MANUFACTURE AND SALE OF ELECTRIC MOTORS, SALES AND DEVELOPMENT OF VARIABLE FREQUENCY DRIVES.**

Original Approval Date: 18-05-2022  
Expiry date of previous cycle: N/A  
Certification Cycle Start Date: 18-05-2022  
Certification Cycle End Date: 17-05-2025  
Subject to the continued satisfactory operation of the organisation's Management System, this certificate is valid until: 17-05-2025

To check this certificate validity please call: +420 210 090 215

Further clarifications regarding the scope of this certificate and the applicability of the management system requirements may be obtained by consulting the organisation.

Version 1 Issue Date: 18-05-2022  
Certificate Number: CZF - 2200117

ISSUING OFFICE ADDRESS: BUREAU VERITAS CERTIFICATION CZ s.r.o., Obchodní 1, 143 02 Praha 4, Czech Republic

1/1

ZERTIFIKAT ◆ CERTIFICATE ◆ 認證證書 ◆ CERTIFICADO ◆ CERTIFICAT



# CERTIFICATE

**TÜV SÜD Slovakia s.r.o.**  
Certification Body for Management Systems  
Accredited by SNAS  
Certificate on accreditation No. Q-011  
certifies that



**VYBO Electric a.s.**  
Radlinského 18  
SK – 052 01 Spišská Nová Ves  
ICO: 45 537 143

has established and applies  
a Quality Management System for

**Manufacture and sale of electric motors.  
Sales and development of variable frequency drives.**

An audit was performed, Report No. 2264/40/22/Q/AS/C  
Proof has been furnished that the requirements  
according to

**STN EN ISO 9001:2016**

are fulfilled. The certificate is valid from 2022-04-14 until 2025-04-13  
Certificate Registration No. Q 2264-1

Bratislava, 2022-04-14

TÜV SÜD Slovakia s.r.o.  
Certification Body for Management Systems  
Member of Group TÜV SÜD  
Jaskóva 6, 821 03 Bratislava

F-Q-019/26

Certificate SK22/3701

The management system of

**VYBO Electric a.s.**  
Radlinského 18  
052 01 Spišská Nová Ves, Slovakia

has been assessed and certified as meeting the requirements of

### EN ISO 50001:2018

For the following activities

**Production & sales of electric motors.  
Sales & development of variable frequency drives.**

Further clarifications regarding the scope of this certificate and the applicability of EN ISO 50001:2018 requirements may be obtained by consulting the organisation.

This certificate is valid from 7 April 2022 until 6 April 2025  
and remains valid subject to satisfactory surveillance audits.  
Recertification audit due a minimum of 60 days  
before the expiration date.  
Issue 1. Certified with SGS since 7 April 2022

Authorised by

Ing. Róbert Bodnár  
Director  
SGS Slovakia spol. s r. o.  
Kýzucká 14, 040 11 Košice, Slovakia  
t +421 55 783 61 11, f +421 55 783 61 20, www.sgs.com

Page 1 of 1



This document is issued by the Company subject to its General Conditions of Certification. Services accessible at [www.sgs.com](http://www.sgs.com) and conditions. Attention is drawn to the limitations of liability, indemnification and jurisdictional issues established therein. The authenticity of this document may be verified at <http://www.sgs.com/certificates/certificate>. Any unauthorized alteration, forgery or falsification of the content or appearance of this document is unlawful and offences may be prosecuted to the fullest extent of the law.