



tel: + 421 907 937 187
e-mail: mv@vyboelectric.eu

www.vyboelectric.com



CONTENTS

Company profile.....	01
Honorary certificates.....	03
Work scenario.....	05
Material processing.....	06
VEV 2 - technical data table.....	07
VEV 2 - install and use.....	09



COMPANY PROFILE

VYBO Electric is a special supplier of industrial electric motors with wide range of products. Plant is located in European Union in the Slovak Republic in Spisska Nova Ves in the Central Eastern part of the country. We have extensive experience in the production of electric motors and in the design of electric drive itself.

The location has been known for the electrotechnical industry and also for the manufacture of electric motors and electrotechnical equipment for over the 120 years. The Slovak Republic is still one of the leading manufacturers of electric and technical equipment.

VYBO Electric is a specialist for high-tech, high-efficiency big power and high voltage motors. The company is one of the leading suppliers of big power and medium, high voltage motors in European union.

HONORARY CERTIFICATE





WORK SCENARIO



MATERIAL PROCESSING

COLD ROLLED SILICON STEEL SHEET

- Non oriented electrical silicon steel: high speed stamping
- Automatic lamination to reduce resistance

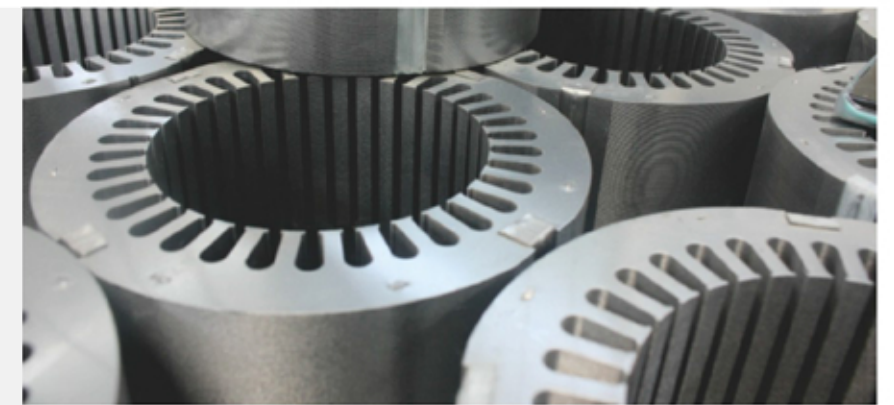

180° GRADE OXYGEN FREE COPPER WIRE

- 180° oxygen free rod vibration motor
- Special line, low temperature rise, strong resistance to penetration



SEIKO BEARING

- Domestic first-line brands, high intensity
- Special bearing for vibration motor
- Can customize SKF, FAG, NSK, etc
- Brand.

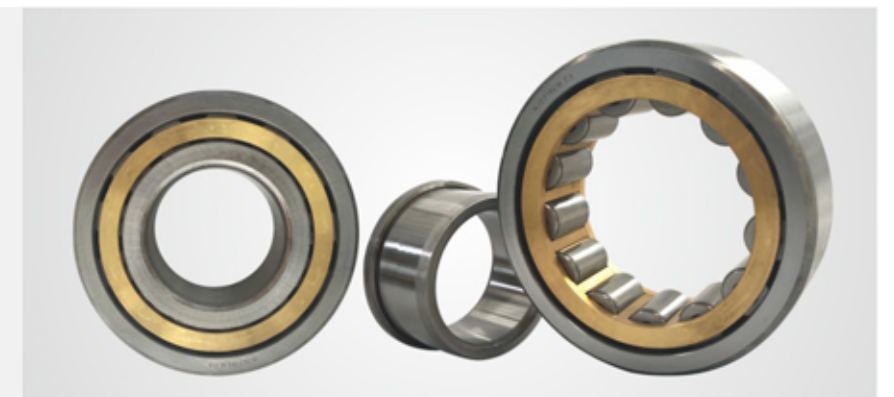

VEV 2

VEV 2 EUROPEAN STANDARD SERIES

VEV 2 series vibration motors are European standard products, using high-strength zinc aluminum alloy as raw materials, which is processed by high-precision aluminum pressure casting process. The weight of the motor is greatly reduced while the motor working capacity is increased.

It has the remarkable characteristics of high protection grade, small volume and long service life.

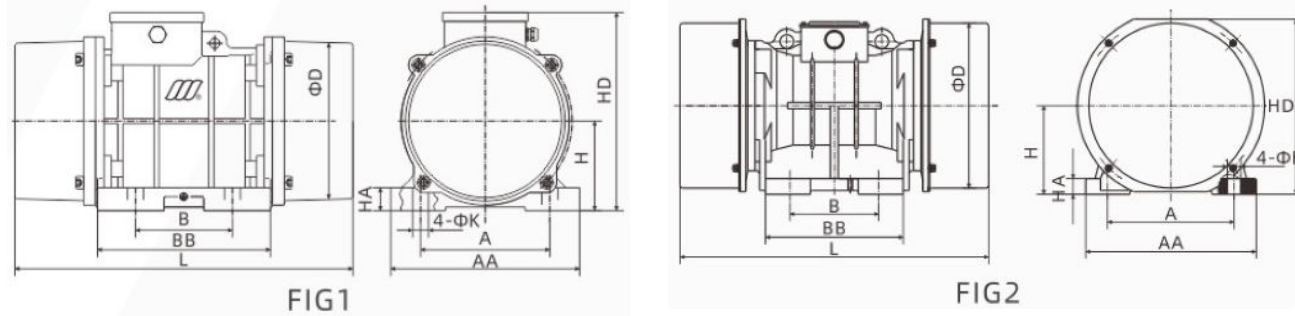

Model	Force (kN)	Power (kW)	Current (A)	Dimensions (mm)										Screw size	Weight	Figure
				A	B	H	AA	BB	HA	HD	L	D	K			
VEV2- 60/3	0.6	0.04	0.25	106	62-74	61	125	123	30	153	211	110	9	M8	5.5	FIG1
VEV2- 100/3	1	0.04	0.25	106	62-74	61	125	123	30	153	211	110	9	M8	5.8	FIG1
VEV2- 200/3	2	0.09	0.35	106	62-74	61	125	123	30	153	211	110	9	M8	7	FIG1
VEV2- 300/3	3	0.16	0.52	125	90	80	155	160	15	183	303	135	12	M10	9.8	FIG1
VEV2- 400/3	4	0.2	0.58	125	90	80	155	160	15	183	303	135	12	M10	10.3	FIG1
VEV2- 500/3	5	0.37	0.96	140	105	90	190	177	23	190	340	160	13	M12	15.8	FIG1
VEV2- 700/3	7	0.45	1.25	140	105	90	190	177	23	190	340	160	13	M12	16.5	FIG1
VEV2- 800/3	8	0.55	1.45	170	120	120	210	180	20	240	409	220	17	M16	38.5	FIG1
VEV2-1200/3	12	0.75	1.85	170	120	120	210	180	20	240	409	220	17	M16	41	FIG1
VEV2-1300/3	13	1.1	2.44	170	120	120	210	180	20	240	409	220	17	M16	41.5	FIG1
VEV2-1600/3	16	1.25	2.94	190	140	140	270	218	25	300	436	260	17	M16	58	FIG1
VEV2-2000/3	20	2	3.75	190	140	140	270	218	25	300	436	260	17	M16	60	FIG1
VEV2-2300/3	23	2	4.44	190	140	140	270	218	25	300	436	260	17	M16	61	FIG1
VEV2-3200/3	32	2.2	5.3	255	155	165	290	232	30	325	542	210	23.5	M22	92	FIG2
VEV2-4000/3	40	2.3	5.3	255	155	190	350	250	32	375	574	354	23.5	M22	107	FIG2
VEV2-5000/3	50	3.5	7.22	255	155	190	350	250	32	375	574	354	23.5	M22	112	FIG2

Model	Force (kN)	Power (kW)	Current (A)	Dimensions (mm)										Screw size	Weight	Figure
				A	B	H	AA	BB	HA	HD	L	D	K			
VEV2- 40/15	0.4	0.03	0.31	106	62-74	61	125	123	30	153	211	110	9	M8	5.8	FIG1
VEV2- 90/15	0.9	0.04	0.31	106	62-74	61	125	123	30	153	211	110	9	M8	7	FIG1
VEV2-200/15	2	0.06	0.49	125	90	80	155	160	15	183	303	135	12	M10	11.8	FIG1
VEV2-250/15	2.5	0.07	0.54	125	90	80	155	160	15	183	303	135	12	M10	13.2	FIG1
VEV2-300/15	3	0.08	0.62	125	90	80	155	160	15	183	303	135	12	M10	16.5	FIG1
VEV2-400/15	4	0.15	0.84	140	105	90	190	177	23	190	340	160	13	M12	19.5	FIG1
VEV2-500/15	5	0.25	1.06	140	105	90	190	177	23	190	340	160	13	M12	21	FIG1
VEV2- 700/15	7	0.37	1.32	170	120	120	210	180	20	240	409	220	17	M16	43	FIG1
VEV2- 800/15	8	0.4	1.36	170	120	120	210	180	20	240	409	220	17	M16	43.5	FIG2
VEV2-1100/15	11	0.4	1.4	170	120	120	210	180	20	240	409	220	17	M16	46.5	FIG2
VEV2-1400/15	14	0.45	1.78	190	140	140	270	218	25	300	436	260	17	M16	61.5	FIG2
VEV2-1700/15	17	0.75	2.16	190	140	140	270	218	25	300	436	260	17	M16	67	FIG2
VEV2-2400/15	34	1	3.2	190	140	140	270	218	25	300	436	260	17	M16	74	FIG2
VEV2-2500/15	25	1.2	3.08	225	155	165	290	232	30	325	542	210	22	M20	91	FIG2
VEV2-3000/15	30	1.5	3.68	225	155	165	290	232	30	325	542	210	22	M20	94	FIG2
VEV2-3800/15	38	1.72	4.15	255	155	190	350	250	32	375	574	354	23.5	M20	130.4	FIG2
VEV2-4300/15	43	1.94	4.5	255	155	190	350	250	32	375	574	354	23.5	M20	134.2	FIG2
VEV2-5500/15	55	2.2	6.5	280	180	190	350	250	32	375	614	354	26	M24	150	FIG2
VEV2-7200/15	72	3	8.5	320	200	200	420	310	31	402	666	373	28	M26	205	FIG2
VEV2-200/1	2	0.05	0.65	140	105	90	190	177	23	190	340	160	13	M12	19.6	FIG1
VEV2-300/1	3	0.16	0.67	170	120	120	210	180	20	240	409	220	17	M16	42.5	FIG2
VEV2-400/1	4	0.25	1.22	170	120	120	210	180	20	240	409	220	17	M16	44	FIG2
VEV2-500/1	5	0.37	1.22	170	120	120	210	180	20	240	449	220	17	M16	48	FIG2
VEV2-800/1	8	0.45	1.42	190	140	140	270	218	25	300	436	260	17	M16	65.5	FIG2
VEV2-1100/1	11	0.55	1.42	190	140	140	270	218	25	300	436	260	17	M16	71.5	FIG2
VEV2-1400/1	14	0.70	1.95	190	140	140	270	218	25	300	486	260	17	M16	81	FIG2
VEV2-1600/1	16	0.75	2.06	190	140	140	270	218	25	300	486	260	17	M16	89	FIG2
VEV2-1620/1	16.2	0.75	2.4	225	155	165	290	232	30	325	542	210	22	M20	93	FIG2
VEV2-2100/1	21	1.1	3.00	225	155	165	290	232	30	325	542	210	22	M20	100	FIG2
VEV2-2600/1	26	1.5	4.1	255	155	190	350	250	32	375	574	354	23.5	M22	148.6	FIG2
VEV2-3000/1	30	1.7	4.5	255	155	190	350	250	32	375	574	354	23.5	M22	155.4	FIG2
VEV2-3800/1	38	2	5.5	280	180	190	350	250	32	375	614	354	26	M24	168	FIG2
VEV2-4700/1	47	2.35	6.5	280	180	190	350	250	32	375	614	354	26	M24	180	FIG2
VEV2-5200/1	52	2.6	6.92	320	200	200	420	310	31	402	666	373	28	M26	280	FIG2
VEV2-6500/1	65	2.9	7.76	320	200	200	420	310	31	402	666	373	39	M26	305	FIG2

EXCITATION FORCE REGULATION

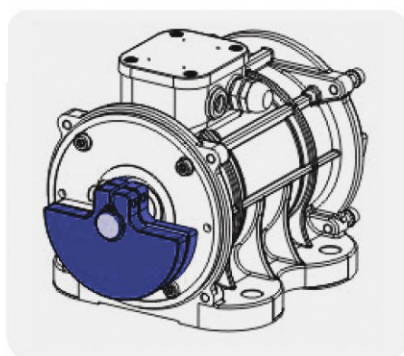

100 % FORCE

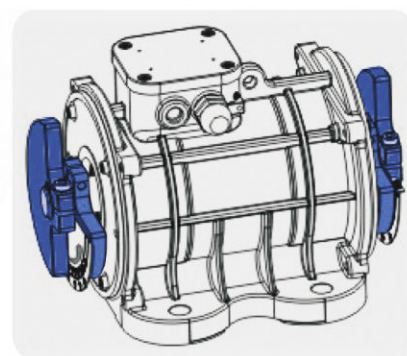

correct adjustment

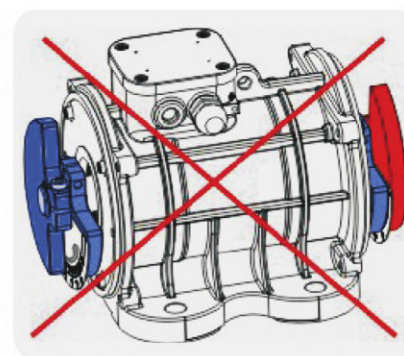

wrong adjustment

Adjust according to the eccentric block indicator.

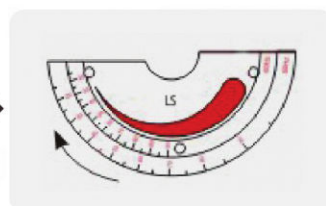

The rotation direction of the eccentric block is opposite to that of the connector.

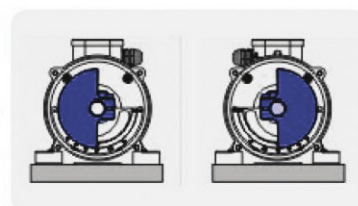

Required force: always adjust from the thicker side to thinner side according to the indicator.

FORCE ADJUSTMENT TABLE

There is a fixed eccentric block and an adjustable eccentric block at each end of the output shaft of the vibration motor. The exciting force can be changed by adjusting the angle between the adjustable eccentric block and the fixed eccentric block.

The angle of the eccentric block is 0° when delivered from the factory, and the excitation force at this time is the rated excitation force F.

The excitation forces at different angles are shown in the table below.

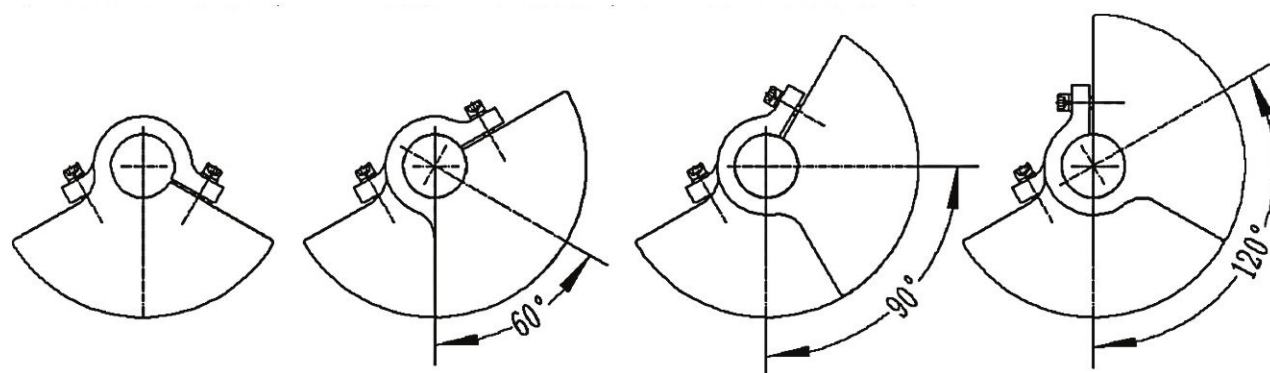

Adjusted unbalanced block angle	0°	60°	90°	120°
Force	F	0.866F	0.707F	0.5F

VIBRATION MOTOR INSTALLATION

Before installing the vibration motor, all power supplies to the equipment shall be cut off and locked, and warning signs shall be given.

- Before installation, check whether there is bruise or moisture during transportation, and whether the fasteners are loose.
- Check whether the nameplate data meets the requirements. Under the condition of no special requirements of the user, the eccentric block position of the vibration motor produced by the company is at the maximum excitation force position marked on the nameplate.
- The installation surface of vibration motor must be firm and flat; The flatness of the mounting surface shall be 0.08mm lower (in this way, when tightening the mounting bolts, the vibration motor can be used to minimize the internal stress of the shell), and the flat plate shall be free of pores and cracks; The mounting surface shall not be less than the foot surface of the vibration motor; Avoid welding in the mounting surface area, otherwise it will affect the flatness of the mounting surface of the vibrating motor.
- Ensure that the installation surface is free of paint and sundries, and ensure that the underside of the vibration motor is clean. Note: after the vibration motor has been installed and wired, it is not allowed to weld on the mounting plate. Welding may cause vibration, motor winding and bearing damage.
- The four foot bolts of the vibration motor shall be selected with corresponding high-strength bolts not lower than grade 8.8 according to the hole diameter, which shall be reliably fastened with a wrench and anti loosening measures shall be taken without any looseness. H80 ~ 110 shall adopt the anti loosening structure of flat pad. H140 ~ 240 shall be fastened with flat cushion and double nuts and locked. Tighten the mounting bolts in the sequence shown in Figure 2. If it is not tightened in the specified sequence, the vibration motor may be damaged. Before installing the vibration motor on the mounting plate, all bolts shall be coated with thread sealant.
- The tightening torque of various relevant bolts has been given in Table 1. Users must tighten the foot bolts according to the corresponding torque during installation.
- MVG series vibration motors have anti drop mounting holes near the junction box. When the user installs the vibration motor higher than 0.2m above the ground, it is recommended to bolt it with a chain hook to prevent the four or six foot bolts of the vibration motor from falling when they are loose, resulting in equipment damage and safety accidents.

Check the bolt tightening torque after 10 to 20 minutes of motor test run. Tighten again if necessary

Metric system			
Screw model	Tightening torque	Screw model	Tightening torque
M6	1	M22	56
M8	2.3	M24	71
M10	5	M27	89
M12	8	M36	190
M16	19	M42	290
M20	38		

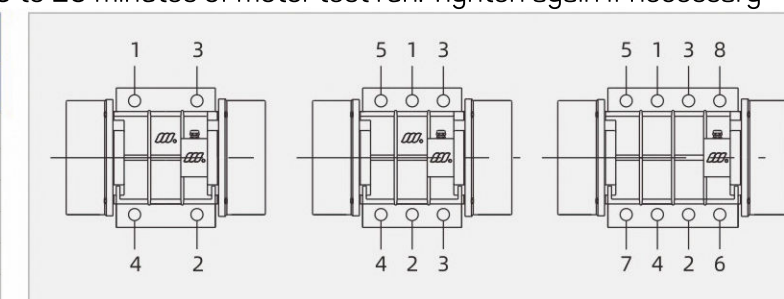

ELECTRICAL CONNECTION

Ensure that the voltage and frequency are consistent with the values on the nameplate of the vibrating motor. Pass the power line through the cable joint, and the nominal section of the cable conductor shall meet the required requirements. Please strictly follow the wiring diagram and tighten the wiring nut with the torque shown in the figure.

Note that the yellow and green wires in the power line should be reliably grounded! Before closing the terminal box cover, make sure that the gasket is placed correctly to ensure that the protection grade is reached.

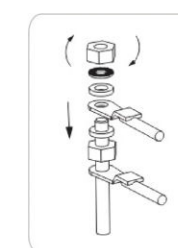
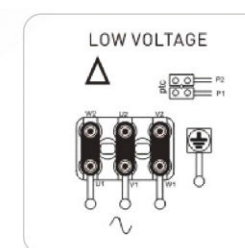
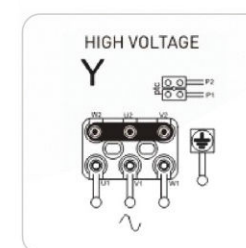

Terminal nut torque		
Screw	Nm	ft*lb
M4	2.5	1.84
M5	4	2.95
M6	5	3.69
M8	6	4.43
M10	8	5.90

OVERLOAD PROTECTION

All vibrating motors must be externally connected with overload protection devices.

When two vibrating motors are used at the same time, each needs to be connected with an overload protection device, and the two overload protection devices are linked, that is, when one vibrating motor stops running, the other vibrating motor will stop running immediately.